



SOPHISTICATED
COFFEE EXPERTISE

EVOLUTION

Ready to meet any challenge





The Franke Evolution leaves no wishes unfulfilled. It belongs to the elite group of coffee machines and impresses gastronomy professionals in three aspects: The Evolution offers above-average performance in a surprisingly compact size. With its perfected technology, there is virtually no task it cannot handle. And finally, it is a true eyecatcher – timeless and elegant. No wonder the Evolution has many admirers in all areas, including restaurants, bars, hotels and caterers. In short, it's a coffee machine with a character.

OPTIMAL HANDLING

The bean hoppers can be removed easily and without additional tools thanks to the integrated slides. They feature optimal glide properties, even with oily bean types.

INDIVIDUALIZED OPERATION

The large, clearly arranged product buttons can be individually programmed and labeled. Whether in self-service operation with a maximum of 6 coffee products or in the operated version with up to 20 different coffee products, you're always in control.

FLEXIBLY VARIABLE

Thanks to the continuously adjustable outlet height from 80 to 150 mm, all the popular sizes of cups and containers can be used. The optimized coffee supply and the combination outlet guarantee that the coffee is always at the right temperature and that the cups are evenly filled, even when using the double-dispenser system.

EASY TO CLEAN

The automatic rinsing and cleaning program for the coffee and milk section simplifies the maintenance and care of the machine. The dispenser is easy to remove and can be safely cleaned in a dishwasher. This ensures optimum hygiene and a consistently high coffee quality. HACCP conformity is guaranteed.

ELABORATE IN EVERY DETAIL

The Evolution offers everything the experienced coffee lover desires and the cool calculator is looking for. This functional, compact machine is timeless in design, and yet focuses entirely on what's essential: producing an unmistakable coffee quality.

FLEXIBLY VARIABLE



EASY TO CLEAN



OPTIMAL HANDLING



INDIVIDUAL OPERATION





COFFEE WITH MILK: DIVERSITY CAN BE THIS EASY

With the intelligent CF milk system, Cappuccino, Café Latte, Latte Macchiato and hot and cold milk are whisked into your cup in an instant. The outlet system jointly dispenses milk and coffee. These ingredients can be drawn simultaneously, either using a single or double dispenser. The milk output sequence is freely programmable – either before, during, or after the coffee. And thanks to permanent cooling, the milk is always fresh.

SYSTEMATIC MILK PREPARATION

The modular CF milk system is easy to operate and to clean – and is ideally integrated into the design of the Evolution. For an immaculate appearance, the automatic rinsing and cleaning program makes sure the milk is processed under totally hygienic conditions at all times. Depending on the setting, the entire milk system is rinsed automatically either each time a product is dispensed or after a certain period of time. The outlet head is easily accessible and can be removed for cleaning.

MILK PREPARATION AT A GLANCE

- Adjustable milk temperature
- Milk outlet for two milk products
- Output of cold milk
- Consistent dosing
- Level monitoring with visual indication on the machine's display
- Automatic cleaning and rinsing program
- Milk products halted when the milk container is empty
- Suitable for self-service with connection to billing systems
- Cup monitoring

Milk solutions

Different solutions for milk storage enable the dispensing of fresh milk to meet all milk needs and space requirements.



Evolution with refrigeration unit KE225 (6 liters) and cup warmer for approx. 80 cups



Evolution with Chill & Cup – Storage of 5 liters of cold milk, with combined cup warmer for approx. 80 cups

PROVEN AND COMPACT

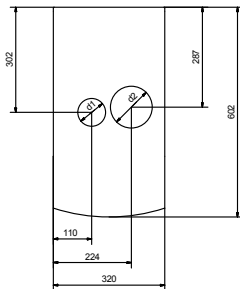
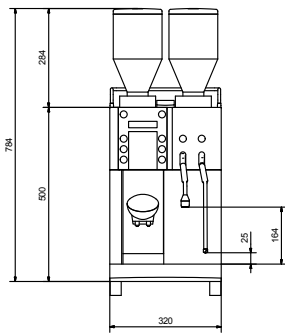
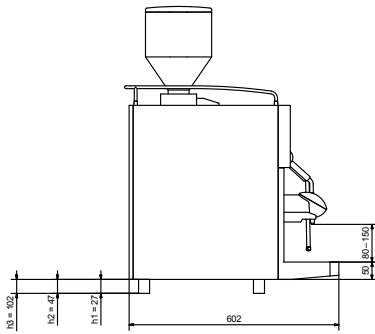

FEATURES OF THE EVOLUTION BASIC AND TOP

	EVOLUTION BASIC	EVOLUTION TOP
Ristretto	180 cups/h	240 cups/h
Espresso	180 cups/h	240 cups/h
Coffee	120 cups/h	180 cups/h
Milk coffee	120 cups/h	150 cups/h
Cappuccino	120 cups/h	150 cups/h
Latte Macchiato	120 cups/h	120 cups/h
Hot water	20 liters/h	25 liters/h
Hot milk	120 cups/h	120 cups/h
Cold milk	150 cups/h	150 cups/h

Number of cups per hour - dependent on drink size and setting

MACHINE MODELS

MODEL	ELECTRICAL CONNECTION	POWER
Evolution Basic	230-240 V 1LN PE 50/60Hz 16 A	3.2 kW
	230-240 V 1LN PE 50/60Hz 10 A	2.2 kW
Evolution Top	230-240 V 1LN PE 50/60Hz 30 A	5.2 kW
	400 V 2LN PE 50/60Hz 16 A	5.2 kW

Other electrical connections upon request

ADD-ON UNITS

TYPES	ELECTRICAL CONNECTION	POWER
Refrigeration unit KE225 (6 liters)	230 V 1LN PE 50/60 Hz 10 A	70 W
Refrigeration unit KE320 (10 liters)	230 V 1LN PE 50/60 Hz 10 A	100 W
Undercounter refrigeration unit UT (10 liters)	230 V 1LN PE 50/60 Hz 10 A	100 W
Chill & Cup (5 liters/80 cups)	230 V 1LN PE 50/60 Hz 10 A	170 W
Base refrigeration unit UKE (5 liters)	230 V 1LN PE 50/60 Hz 10 A	70 W
Cup warmer (50-80 cups)	230 V 1LN PE 50/60 Hz 10 A	150 W
Chocolate dispenser Exquisit	230 V 1LN PE 50/60 Hz 16 A	2.4 kW

WATER CONNECTION

Supply line	Metal hose with union nut G3/8", L = 1.5 m
Water pressure	0.8 to 8.0 bar (80 to 800 kPa)
Water hardness	Max. 7°dH 13°fH
Chlorine content	Max. 100 mg/l
Ideal pH value	7

WATER DRAIN

Wastewater hose	d = 16 mm, L = 2000 mm
-----------------	------------------------